

8A

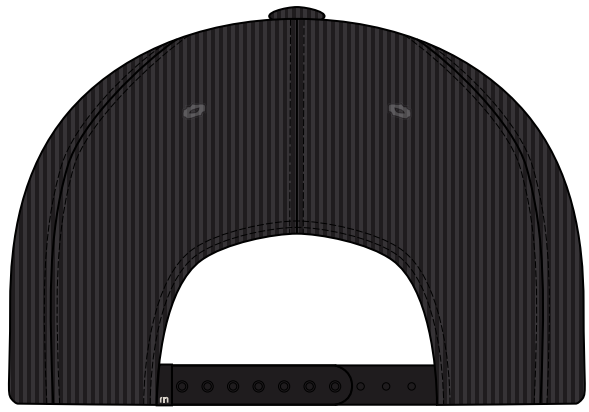

STYLE#:	XXX
NAME:	XXX
COLOR:	BLACK
CODE:	0BLK
WHSL:	XXX
CATALOG FABRIC:	
VENDOR:	FLEXFIT
COST:	
MARGIN:	
HANGTAGS:	
FABRIC MILL:	
FABRIC CODE:	
FABRIC CONTENT:	CORDUROY
SAMPLE SETS:	

RANKINGS	
ECOMM:	XXX
RETAIL:	XXX
TERRITORY:	XXX
NATIONAL:	XXX
COMP/DETAILS:	XXX



8B

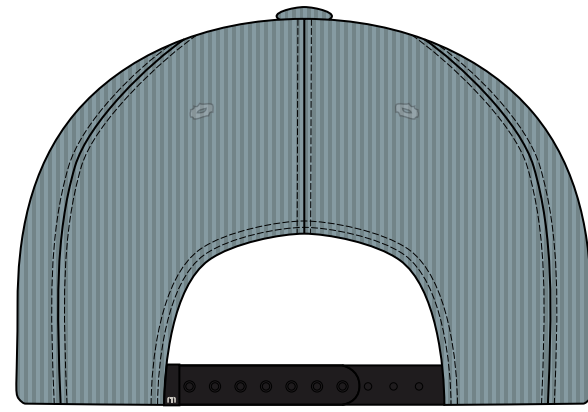

STYLE#:	XXX
NAME:	XXX
COLOR:	ARONA
CODE:	XXX
WHSL:	XXX
CATALOG FABRIC:	
VENDOR:	FLEXFIT
COST:	
MARGIN:	
HANGTAGS:	
FABRIC MILL:	
FABRIC CODE:	
FABRIC CONTENT:	CORDUROY
SAMPLE SETS:	

RANKINGS	
ECOMM:	XXX
RETAIL:	XXX
TERRITORY:	XXX
NATIONAL:	XXX
COMP/DETAILS:	XXX



8C



STYLE#:	XXX
NAME:	XXX
COLOR:	TOTAL ECLIPSE
CODE:	XXX
WHSL:	XXX
CATALOG FABRIC:	
VENDOR:	FLEXFIT
COST:	
MARGIN:	
HANGTAGS:	
FABRIC MILL:	
FABRIC CODE:	
FABRIC CONTENT:	CORDUROY
SAMPLE SETS:	

RANKINGS	
ECOMM:	XXX
RETAIL:	XXX
TERRITORY:	XXX
NATIONAL:	XXX
COMP/DETAILS:	XXX



10A

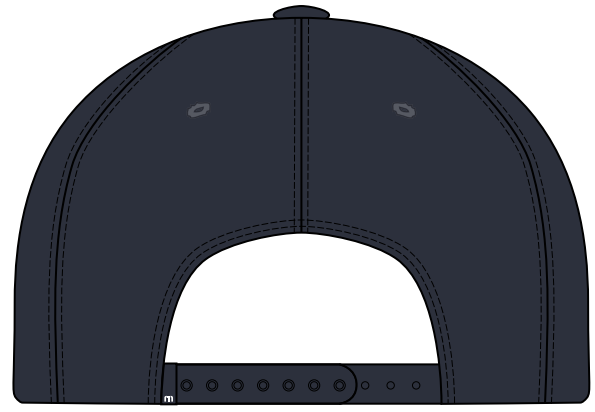

STYLE#:	XXX
NAME:	XXX
COLOR:	TOTAL ECLIPSE
CODE:	XXX
WHSL:	XXX
CATALOG FABRIC:	

VENDOR:	FLEXFIT
COST:	
MARGIN:	
HANGTAGS:	
FABRIC MILL:	
FABRIC CODE:	
FABRIC CONTENT:	SKEETER

SAMPLE SETS:	

RANKINGS	
ECOMM:	XXX
RETAIL:	XXX
TERRITORY:	XXX
NATIONAL:	XXX
COMP/DETAILS:	XXX



10B

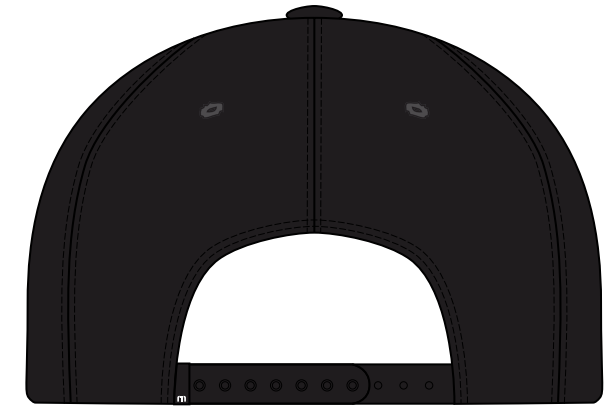

STYLE#:	XXX
NAME:	XXX
COLOR:	BLACK
CODE:	XXX
WHSL:	XXX
CATALOG FABRIC:	

VENDOR:	FLEXFIT
COST:	
MARGIN:	
HANGTAGS:	
FABRIC MILL:	
FABRIC CODE:	
FABRIC CONTENT:	SKEETER

SAMPLE SETS:	

RANKINGS	
ECOMM:	XXX
RETAIL:	XXX
TERRITORY:	XXX
NATIONAL:	XXX
COMP/DETAILS:	XXX



10C

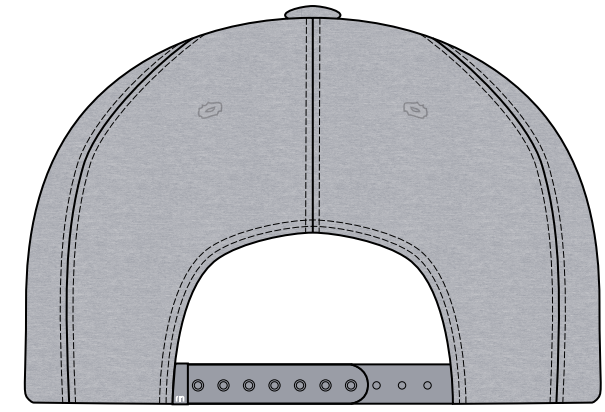

STYLE#:	XXX
NAME:	XXX
COLOR:	HTR GRAY
CODE:	XXX
WHSL:	XXX
CATALOG FABRIC:	

VENDOR:	FLEXFIT
COST:	
MARGIN:	
HANGTAGS:	
FABRIC MILL:	
FABRIC CODE:	
FABRIC CONTENT:	SKEETER

SAMPLE SETS:	

RANKINGS	
ECOMM:	XXX
RETAIL:	XXX
TERRITORY:	XXX
NATIONAL:	XXX
COMP/DETAILS:	XXX



11A



STYLE#:	XXX
NAME:	XXX
COLOR:	BLACK
CODE:	
WHSL:	XXX
CATALOG FABRIC:	

VENDOR:	MADISON88
COST:	
MARGIN:	
HANGTAGS:	
FABRIC MILL:	
FABRIC CODE:	
FABRIC CONTENT:	KNIT

SAMPLE SETS:	

RANKINGS	
ECOMM:	XXX
RETAIL:	XXX
TERRITORY:	XXX
NATIONAL:	XXX
COMP/DETAILS:	XXX



11B



STYLE#:	XXX
NAME:	XXX
COLOR:	BLACK
CODE:	
WHSL:	XXX
CATALOG FABRIC:	

VENDOR:	MADISON88
COST:	
MARGIN:	
HANGTAGS:	
FABRIC MILL:	
FABRIC CODE:	
FABRIC CONTENT:	KNIT

SAMPLE SETS:	

RANKINGS	
ECOMM:	XXX
RETAIL:	XXX
TERRITORY:	XXX
NATIONAL:	XXX
COMP/DETAILS:	XXX



12A

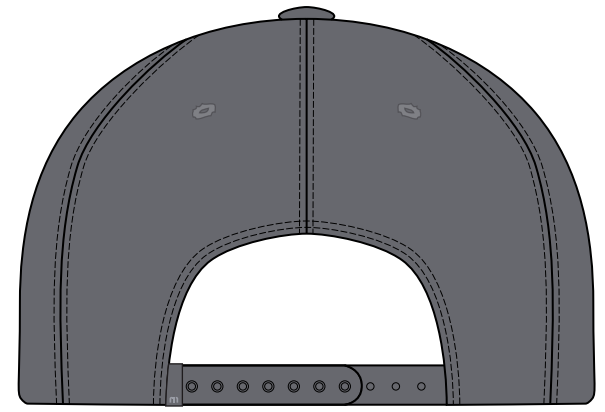

STYLE#:	XXX
NAME:	XXX
COLOR:	DARK GRAY
CODE:	XXX
WHSL:	XXX
CATALOG FABRIC:	
VENDOR:	FLEXFIT
COST:	
MARGIN:	
HANGTAGS:	
FABRIC MILL:	
FABRIC CODE:	
FABRIC CONTENT:	BERMUDA- FABRIC SNAPBACK
SAMPLE SETS:	

RANKINGS	
ECOMM:	XXX
RETAIL:	XXX
TERRITORY:	XXX
NATIONAL:	XXX
COMP/DETAILS:	XXX



12B

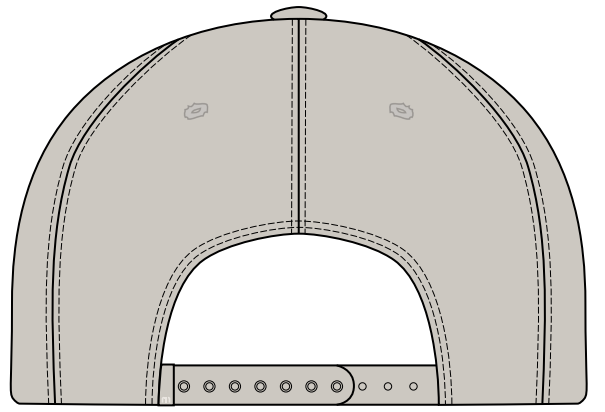

STYLE#:	XXX
NAME:	XXX
COLOR:	MOONBEAM
CODE:	XXX
WHSL:	XXX
CATALOG FABRIC:	
VENDOR:	FLEXFIT
COST:	
MARGIN:	
HANGTAGS:	
FABRIC MILL:	
FABRIC CODE:	
FABRIC CONTENT:	BERMUDA- FABRIC SNAPBACK
SAMPLE SETS:	

RANKINGS	
ECOMM:	XXX
RETAIL:	XXX
TERRITORY:	XXX
NATIONAL:	XXX
COMP/DETAILS:	XXX



12C

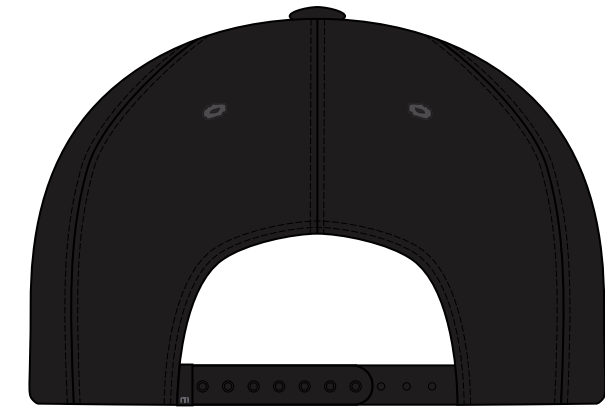

STYLE#:	XXX
NAME:	XXX
COLOR:	BLACK
CODE:	XXX
WHSL:	XXX
CATALOG FABRIC:	
VENDOR:	FLEXFIT
COST:	
MARGIN:	
HANGTAGS:	
FABRIC MILL:	
FABRIC CODE:	
FABRIC CONTENT:	BERMUDA- FABRIC SNAPBACK
SAMPLE SETS:	

RANKINGS	
ECOMM:	XXX
RETAIL:	XXX
TERRITORY:	XXX
NATIONAL:	XXX
COMP/DETAILS:	XXX



13A

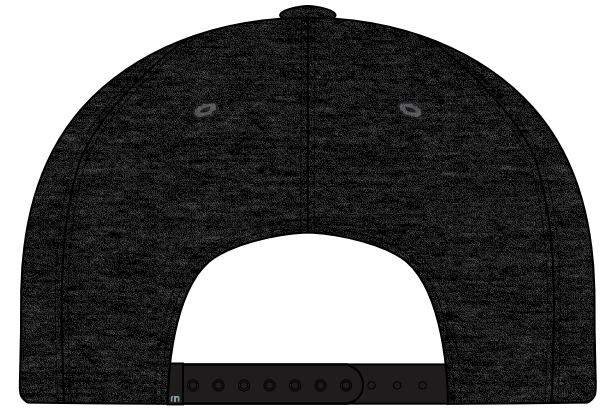

STYLE#:	XXX
NAME:	XXX
COLOR:	HTR BLACK
CODE:	XXX
WHSL:	XXX
CATALOG FABRIC:	

VENDOR:	FLEXFIT
COST:	
MARGIN:	
HANGTAGS:	
FABRIC MILL:	
FABRIC CODE:	
FABRIC CONTENT:	TM MELANGE SPAN

SAMPLE SETS:	

RANKINGS	
ECOMM:	XXX
RETAIL:	XXX
TERRITORY:	XXX
NATIONAL:	XXX
COMP/DETAILS:	XXX



QUIET SHADE

ARONA

13B

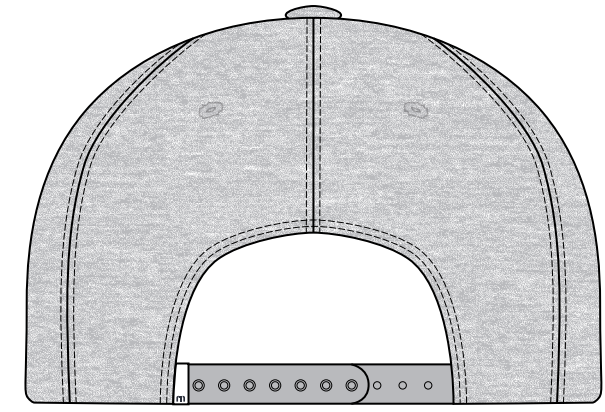

STYLE#:	XXX
NAME:	XXX
COLOR:	HTR LIGHT GRAY
CODE:	XXX
WHSL:	XXX
CATALOG FABRIC:	

VENDOR:	FLEXFIT
COST:	
MARGIN:	
HANGTAGS:	
FABRIC MILL:	
FABRIC CODE:	
FABRIC CONTENT:	TM MELANGE SPAN

SAMPLE SETS:	

RANKINGS	
ECOMM:	XXX
RETAIL:	XXX
TERRITORY:	XXX
NATIONAL:	XXX
COMP/DETAILS:	XXX



14A

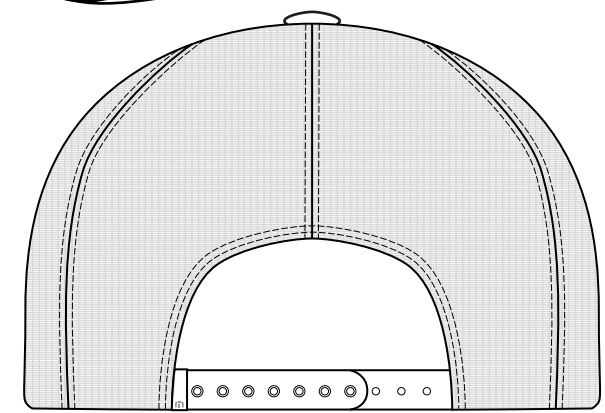
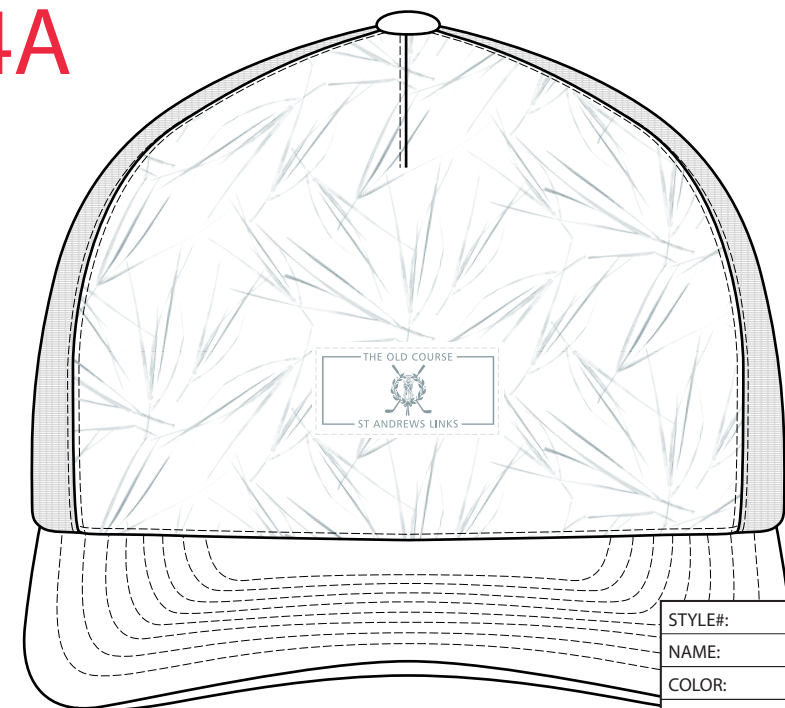

STYLE#:	XXX
NAME:	XXX
COLOR:	WHITE
CODE:	XXX
WHSL:	XXX
CATALOG FABRIC:	
VENDOR:	FLEXFIT
COST:	XXX
MARGIN:	XXX
HANGTAGS:	XXX
FABRIC MILL:	XXX
FABRIC CODE:	XXX
FABRIC CONTENT:	SKEETER W/ SPAN MESH
SAMPLE SETS:	



RANKINGS	
ECOMM:	XXX
RETAIL:	XXX
TERRITORY:	XXX
NATIONAL:	XXX
COMP/DETAILS:	XXX

14B

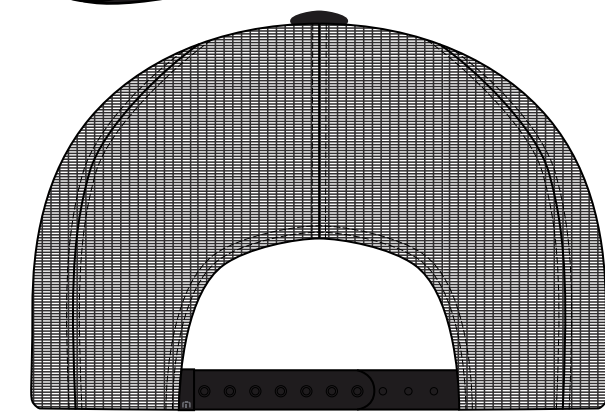

STYLE#:	XXX
NAME:	XXX
COLOR:	BLACK
CODE:	XXX
WHSL:	XXX
CATALOG FABRIC:	
VENDOR:	FLEXFIT
COST:	XXX
MARGIN:	XXX
HANGTAGS:	XXX
FABRIC MILL:	XXX
FABRIC CODE:	XXX
FABRIC CONTENT:	SKEETER W/ SPAN MESH
SAMPLE SETS:	



RANKINGS	
ECOMM:	XXX
RETAIL:	XXX
TERRITORY:	XXX
NATIONAL:	XXX
COMP/DETAILS:	XXX

14C

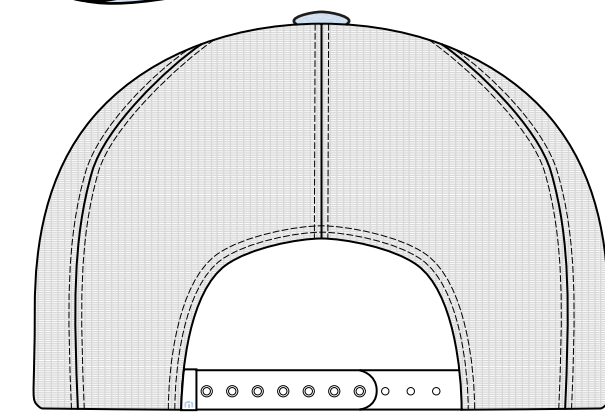
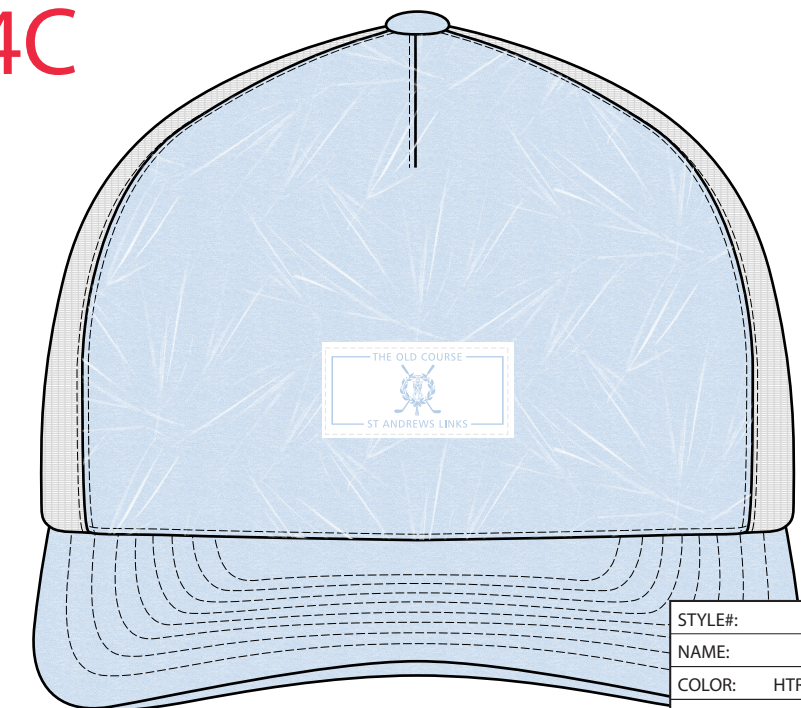

STYLE#:	XXX
NAME:	XXX
COLOR:	HTR BEL AIR BLUE
CODE:	XXX
WHSL:	XXX
CATALOG FABRIC:	
VENDOR:	FLEXFIT
COST:	XXX
MARGIN:	XXX
HANGTAGS:	XXX
FABRIC MILL:	XXX
FABRIC CODE:	XXX
FABRIC CONTENT:	SKEETER W/ SPAN MESH
SAMPLE SETS:	



RANKINGS	
ECOMM:	XXX
RETAIL:	XXX
TERRITORY:	XXX
NATIONAL:	XXX
COMP/DETAILS:	XXX